



DISABLED TOILET PORTABLE

FEATURES AS1428 compliant

- Structural Engineer Certified Steel Frame.
- Australian Standards Power and LED Lighting.
- Australian Standards Plumbing, WELS Certified fixtures.
- Four lifting lugs, one in each corner, + forklift pockets
- Walls: EPS-insulated panels clad in protective powder-coated steel sheet.
- Roof: Insulation with a protective 3mm steel sheet finished with zinc-rich epoxy paint.

FINISHES

- Ceiling: Decorative panel finish
- Floor: Vinyl flooring
- Internal walls: Marble look cladding

FIXTURES & FITTINGS

- Accessible
- Toilet with backrest and handrails
- Hand basin with overhead mirror
- Toilet roll holders
- Wall mounted Toilet brush
- Lockable entry door with vented
- Two Openable windows

Final connection of power, water and drainage by others.

OFFGRID Capable can be connected to Solar, Septic and Tank water

Form 7 is to be provided by the plumber connecting the structure to mains

National 3 Years Structural Warranty

DIMENSIONS

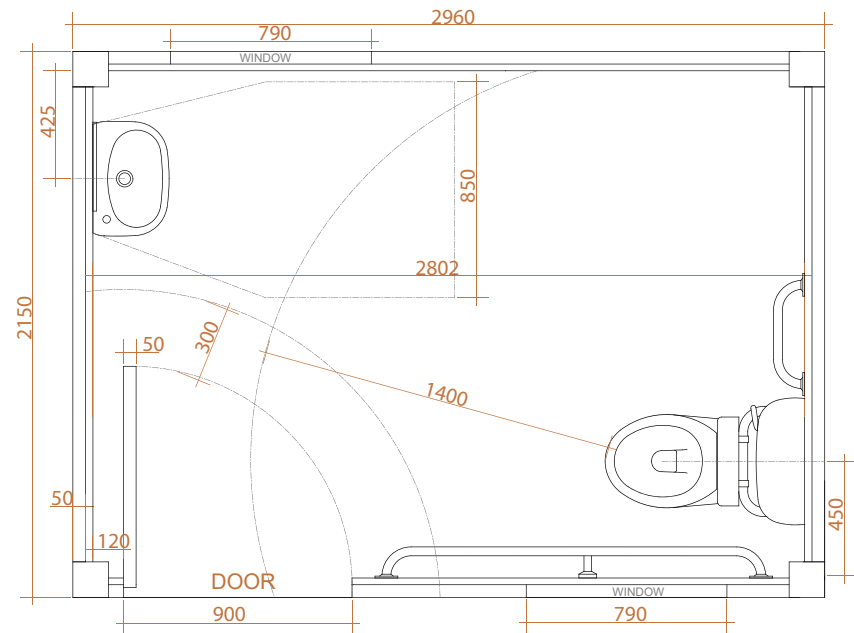
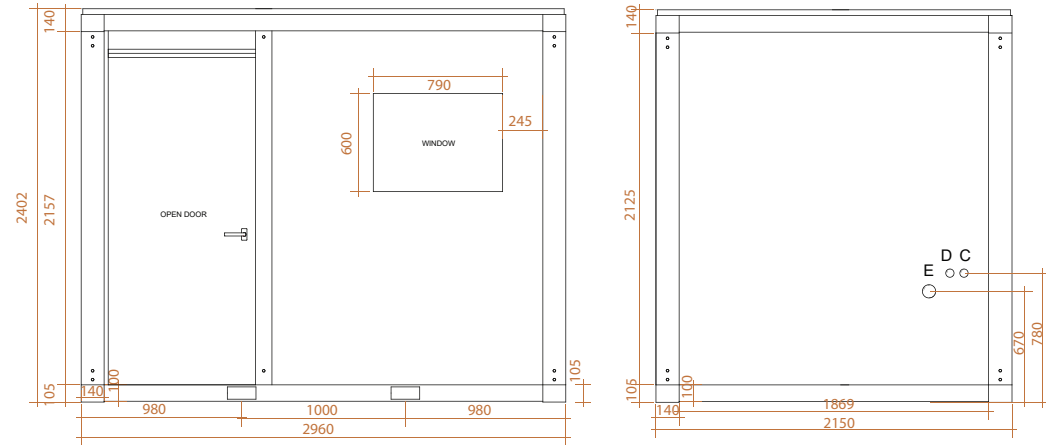

L(m)	W(m)	H(m)	kg
3	2.2	2.45	905



Due to continued product development and improvements, images on display may vary slightly from the actual product. DECKBOSS®, ramps, patios, trailers, furniture, and air conditioning units are not included. These may be found as accessories..